



VerSys® Fiber Metal Taper Hip Prosthesis

Surgical Technique



VerSys Fiber Metal Taper Hip Prosthesis Surgical Technique

Table of Contents

Preoperative Planning	2
Determination of Leg Length	2
Determination of Abductor Muscle Tension and Femoral Offset	3
Component Size Selection/ Templating	3
Surgical Technique	5
Incision	5
Exposure of the Hip Joint	5
Determination of Leg Length	5
Osteotomy of the Femoral Neck	5
Preparation of the Femur	7
Intramedullary Reaming (Optional)	8
Attachment of the Rasp Alignment Tip (Optional)	10
Femoral Rasping	10
Trial Reduction	11
Insertion of the Femoral Component	12
Attachment of the Femoral Head	12
Wound Closure	12
Postoperative Management	12
VerSys Fiber Metal Taper Specifications	13
Fiber Metal Taper — Standard Offset	13
Fiber Metal Taper — Extended Offset	13

Preoperative Planning

Effective preoperative planning allows the surgeon to predict the impact of different interventions in order to perform the joint restoration in the most accurate and safest manner. Optimal femoral stem fit, the level of the femoral neck cut, the prosthetic neck length, and the femoral component offset can be evaluated through preoperative radiographic analysis. Preoperative planning also allows the surgeon to have the appropriate implants available at surgery.

The objectives of preoperative planning include:

1. determination of leg length,
2. establishment of appropriate abductor muscle tension and femoral offset, and
3. determination of the anticipated component sizes.

The overall objective of preoperative planning is to enable the surgeon to gather anatomic parameters which will allow accurate intraoperative placement of the femoral implant.

Determination of Leg Length

Determining the preoperative leg length is essential for restoration of the appropriate leg length during surgery. For most patients, leg lengths are not equal. If leg lengths are equal in both the recumbent and standing positions, the leg length determination is simplified. If there are concerns regarding other lower extremity abnormalities, such as equinus of the foot or significant flexion or varus/valgus deformities of the knee, perform further radiographic evaluation to aid in the determination of preoperative leg length status.

An A/P pelvic radiograph often gives enough documentation of leg length inequality to proceed with surgery. If more information is needed, a scanogram or CT evaluation of leg length may be helpful. From the clinical and radiographic information on leg lengths, determine the appropriate correction, if any, to be achieved during surgery.

If the limb is to be significantly shortened, osteotomy and advancement of the greater trochanter may be necessary. If the limb is shortened without osteotomy and advancement of the greater trochanter, the abductors will be lax postoperatively, and the risk of dislocation will be high. Also, gait will be compromised by the laxity of the abductors.

If leg length is to be maintained or increased, it is usually possible to perform the operation successfully without osteotomy of the greater trochanter. However, if there is some major anatomic abnormality, osteotomy of the greater trochanter may be helpful.

Determination of Abductor Muscle Tension and Femoral Offset

Once the requirements for establishing the desired postoperative leg length have been decided, the next step is to consider the requirement for abductor muscle tension. When the patient has a very large offset between the center of rotation of the femoral head and the line that bisects the medullary canal, the insertion of a femoral component with a lesser offset will, in effect, medialize the femoral shaft. To the extent that this occurs, laxity in the abductors will result.

VerSys Fiber Metal Taper stems are offered in two offsets (standard and extended) in a 135-degree neck angle. This versatility in offset and length enables the surgeon to reproduce almost any offset encountered.

Although rare, it may not be possible to restore offset in patients with an unusually large preoperative offset or with a severe varus deformity. In such cases, the tension in the abductors can be increased by lengthening the limb, a method that is especially useful when the involved hip is short. If this option is not advisable and if the disparity is great between the preoperative offset and the offset achieved at surgery by using the longest head-neck implant possible, some surgeons may choose to osteotomize and advance the greater trochanter to eliminate the slack in the abductor muscles. Technical variations in the placement of the acetabular components can also reduce the differences in offset.

Component Size Selection/ Templating

Preoperative planning for insertion of a cementless femoral component requires at least two views of the involved femur; an anterior/posterior (A/P) view of the pelvis centered at the pubic symphysis, and a frog leg lateral view on an 11x17-inch cassette. Both views should show at least 8 inches of the proximal femur. In addition, it may be helpful to obtain an A/P view of the involved side with the femur internally rotated. This compensates for naturally occurring femoral anteversion and provides a more accurate representation of the true medial to lateral dimension of the metaphysis.

When templating, magnification of the femur will vary depending on the distance from the x-ray source to the film, and the distance from the patient to the film. The VerSys Hip System templates (Fig. 1) use standard 20 percent magnification, which is near the average magnification on most clinical x-rays.



Fig. 1

Large patients and obese patients may have magnification greater than 20 percent because their osseous structures are farther away from the surface of the film. Similarly, smaller patients may have magnification less than 20 percent. To better determine the magnification of any x-ray film, use a standardized marker at the level of the femur. (Templates of 15 and 10 percent magnification can be obtained by special order.)

Preoperative planning is important in choosing the optimal acetabular component, and in providing an estimation of the range of acetabular components that might ultimately be required.

The initial templating begins with the A/P roentgenogram. Superimpose the acetabular templates sequentially on the pelvic x-ray with the acetabular component in approximately 40 degrees of abduction. Range of motion and hip stability are optimized when the socket is placed in approximately 35 to 45 degrees of abduction. Assess several sizes to estimate which acetabular component will provide the best fit for maximum coverage. In most cases, select the largest component possible, being certain that the outside diameter isn't too large to seat completely in the acetabulum. (Refer to the various Zimmer Acetabular System surgical techniques for specific details on acetabular reconstruction.)

Consider the position and thickness of the acetabular component in estimating the optimum femoral neck length to be used. (To simplify this, the acetabular templates are on a separate acetate sheet from the femoral templates.) Mark the acetabular size and position, and the center of the head on the x-rays. This allows any femoral component to be matched with the desired acetabular component by placing the femoral template over the acetabular template. This will provide the best estimation of femoral component size and head-neck length necessary to achieve the correct leg length.

The VerSys Hip System includes several head diameters. In most patients with an average-sized acetabulum, consider a femoral head with an intermediate diameter, such as 28mm or 32mm. The intermediate femoral heads allow the use of an acetabular component with an outside diameter small enough to seat completely in the bone while also allowing for a polyethylene liner of sufficient thickness.

In special circumstances, such as the treatment of small patients and patients with congenital hip dysplasia and small acetabular volume, it is preferable to use a 22mm diameter head to allow for adequate polyethylene thickness.

The specific objectives in templating the femoral component include:

- 1) determining the anticipated size of the implant to be inserted, and
- 2) determining the height of the implant in the femur and the location of the femoral neck osteotomy. Now select the appropriate femoral template. The VerSys Fiber Metal Taper Hip Prosthesis is available in twelve standard body sizes (9 through 20mm) and ten large metaphyseal (LM) sizes (11 through 20mm).

The femoral templates show the neck length and offset for each of the head/neck combinations (-3.5 to +10.5mm, depending on head diameter). Note that skirts are present on +10.5mm heads, and on the +3.5mm size 22mm head.

To estimate the femoral implant size, assess both the distal stem size and the body size on the A/P radiograph, and then check the stem size on the lateral radiograph. Superimpose the template on the isthmus and estimate the appropriate size of the femoral stem. The stem of the femoral component should fill, or nearly fill, the medullary canal in the isthmus area on the A/P x-ray film. Next, assess the fit of the body in the metaphyseal area. The medial portion of the body of the component should fill the proximal metaphysis as fully as possible, compatible with the anatomic endosteal contours of that region.

Next, check the fit of the stem on the lateral x-ray. If the lateral x-ray reveals that the A/P dimension of the isthmus is greater than the medial-lateral (M/L) dimension shown on the A/P film, it may be advantageous to increase the size of the stem to better fill the isthmus. Template the next larger size femoral component on the A/P x-ray to determine the amount of cortical bone that would be removed by reaming to this size. The cortical thickness of the walls must be great enough to allow for additional reaming. If a larger stem would better fill the isthmus, it is preferable to insert the larger stem. This can be accomplished by enlarging the isthmus in the M/L dimension with intramedullary drills. When a larger size is chosen to better fill the isthmus on the lateral x-ray, reevaluate the A/P x-ray to ensure that the fit of the proximal and distal bodies is acceptable.

Careful attention during this process helps the surgeon achieve the goal of implanting a stem that will provide maximum stability and contact with the host bone.

After establishing the proper size of the femoral component, determine the height of its position in the proximal femur and the amount of offset needed to provide adequate abductor muscle tension. Generally, if the leg length and offset are to remain unchanged, the center of the head of the prosthesis should be at the same level as the center of the femoral head of the patient's hip. This should also correspond to the center of rotation of the templated acetabulum. To lengthen the limb, raise the template proximally. To shorten the limb, shift the template distally. The extended offset option offers lateral translation of 5mm. This allows for an offset increase of 5mm without changing the vertical height or leg length. The femoral head lengths will also affect leg length and offset.

Once the height has been determined, note the distance in millimeters from the underside of the collar to the top of the lesser trochanter by using the millimeter scale on the template. For example, one might decide from the templating that a 52mm OD socket, with a size 15 prosthesis and a +3.5 x 28mm diameter femoral head, placed 15mm above the lesser trochanter, are the appropriate choices.

Proximal/distal adjustments in prosthesis position can reduce the need for a femoral head with a skirt. (The skirted heads allow less range of motion than the non-skirted heads which may increase the chance of dislocation.)

Surgical Technique

Incision

In total hip arthroplasty, exposure can be achieved through a variety of methods based on the surgeon's preference. The VerSys Fiber Metal Taper Hip Prosthesis can be implanted using most surgical approaches.

Exposure of the Hip Joint

Develop the exposure of the posterior capsule. To facilitate this, place the leg in internal rotation. The key landmark for division of the short external rotators is the tendon of the piriformis muscle. This tendon runs parallel to the posterior border of the gluteus medius and can be readily palpated as it approaches the posterior superior portion of the greater trochanter. Retract the gluteus medius superiorly and identify the tendon of the piriformis.

Determination of Leg Length

Establish landmarks and obtain measurements before dislocation of the hip so that, after reconstruction, a comparison of leg length and femoral shaft offset can be obtained. From this comparison, adjustments can be made to achieve the goals established during preoperative planning. There are several methods to measure leg length. One method is to fix a leg length caliper to the wing of the ilium. Take baseline measurements to a cautery mark at the base of the greater trochanter while marking the position of the lower limb on the table.

Osteotomy of the Femoral Neck

A common technical error in total hip replacement surgery is insertion of the femoral component in a varus position. The likelihood of this error can be reduced if visualization of the posterior femoral neck is improved. To accomplish this, remove all of the remaining soft tissue from the posterior femoral neck, exposing the intertrochanteric crest and the junction between the femoral neck and greater trochanter. Release some of the inferior capsule to expose the lesser trochanter. When the ideal position of the appropriately selected femoral component was determined during the preoperative planning, the distance between the top surface of the lesser trochanter and the level of the collar was noted. In the example used, this measurement was 15mm. Use this information to determine the level for the femoral neck osteotomy.

The hip is dislocated in flexion, internal rotation, and adduction. The tibia is placed perpendicular to the femur. Then direct the foot toward the ceiling, which delivers the proximal femur into the wound.

Superimpose the *VerSys* Osteotomy Guide (Fig. 2) on the femur. This guide is a metal replica of the acetate template.

There are two criteria for positioning the guide: First, determine the varus or valgus relationship so the center line of the femoral stem overlies the diaphyseal mid-line bisecting the longitudinal axis of the medullary canal. Palpate both the medial and lateral cortices of the femur in the region of the isthmus through the bulk of the vastus lateralis muscle group to determine the distal position of the Osteotomy Guide.

Second, once neutral alignment has been determined, move the template proximally or distally to the correct height, as determined by preoperative planning. The Osteotomy Guides have a linear scale starting at the collar and running distally along the medial edge. This scale is identical to that used preoperatively on the acetate template. Align the appropriate hole (see Table 1) with the center of rotation of the femoral head. All holes on the Osteotomy Guide refer to +0 head center. The tip of the greater trochanter should coincide with the mark designated as “STD” (for standard) on the lateral edge of the Osteotomy Guide. (The “EXT”, “XEXT”, “LOW”, “REV”*, and “LD” markings correspond to the extended offset, extra extended offset, low head center, revision, and low demand/fracture implants.)

Table 1 - Center of Rotation

Head Center Marking	Stem Style/Offset
STD**	Standard Offset
EXT**	Extended Offset
XEXT	Extra Extended Offset
LOW	Low Head Center
REV†	Revision
LD	Low Demand/Fracture

**Offerings for Fiber Metal Taper Hip Prosthesis

†Do not use REV marking with this implant



Fig. 2

*Revision marking refers to obsoleted stem part numbers 84-7843-11/18,20-09.

This alignment of the Osteotomy Guide would be appropriate for most femurs that have a neck shaft angle of 135 degrees. However, if the femur has a neck shaft angle more than or less than 135 degrees, adjustments to the position of the Osteotomy Guide should be made. Since the desired position, in the example used, of the height of the femoral component is 15mm proximal to the top of the lesser trochanter, adjust the template proximally and distally until that relationship has been established. At that point, use electrocautery to inscribe a line across the femoral neck parallel to the under surface of the Osteotomy Guide.

Using the inscribed line as a guide, perform the osteotomy of the femoral neck. To prevent possible damage to the greater trochanter, stop the cut as the saw approaches the greater trochanter. Remove the saw and either

bring it in from the superior portion of the femoral neck to complete the osteotomy cut, or use an osteotome to finish the cut.

Preparation of the Femur

To appropriately insert the femoral prosthesis, adequate exposure of the proximal femur must be obtained. The femur should extend out of the wound, and soft tissue should be removed from the medial portion of the greater trochanter and lateral portion of the femoral neck. It is crucial to adequately visualize this area so the correct insertion site for femoral reaming can be located. Refer to the preoperative planning at this point. Identify the mid-femoral shaft extension intraoperatively

as viewed on the A/P and lateral radiographs. This is usually in the area of the piriformis tendon insertion in the junction between the medial trochanter and lateral femoral neck. Use the Box Osteotome (Fig. 3), Trochanteric Router, or Burr to remove this medial portion of the greater trochanter and lateral femoral neck.

The opening must be large enough for the passage of each sequential Rasp to ensure neutral rasp/implant alignment. However, the opening should not be significantly larger than the Rasp or implant. An insufficient opening may result in varus stem positioning. Before using the next size Rasp, be sure that the opening is large enough. If it is not, use the Box Osteotome again.

After removing the cortical bone, insert the Tapered Awl (Fig. 4) or Curette (Fig. 5) to open the medullary canal. This will provide a reference for the direction of femoral rasping.



Fig. 3



Fig. 4



Fig. 5

Intramedullary Reaming (Optional)

Depending upon the geometry of the distal femur and the surgeon's preference, intramedullary reaming may not be necessary.

The *VerSys* Fiber Metal Taper stem has a distal taper which begins at the transition point between the corundum and polished surfaces of the prosthesis. At this transition point, the prosthesis begins to get smaller than the rasp. As a result, the contact between the prosthesis and distal medullary canal is minimized.

Because of this distal rasp-to-prosthesis relationship resulting from the taper, the objectives of intramedullary reaming are different than they would be for a prosthesis with a distal cylindrical geometry. The specific objectives for reaming of the *VerSys* Fiber Metal Taper Prosthesis are:

1. Helps insure that the prosthesis is placed in a neutral position within the femur. Failure to properly ream the femur in line with the longitudinal axis of the medullary canal risks placing the femoral component in varus or valgus alignment.
2. Provides feedback to the surgeon regarding the size of the distal medullary canal which may help to determine the appropriate size prosthesis.
3. Removes any obstacles in the distal intramedullary canal that may cause impingement which will prevent the prosthesis from seating correctly.

The Intramedullary Reamers have depth marks that correspond with the length of each prosthesis (see Table 2).

To ream the appropriate length of canal, the Reamer should be advanced at least until the applicable depth mark is just below the medial portion of the osteotomy. The following table shows how the reamer marks correspond to each porous implant. A similar sizing legend is etched on the most proximal aspect of the Reamer near the reamer size label.

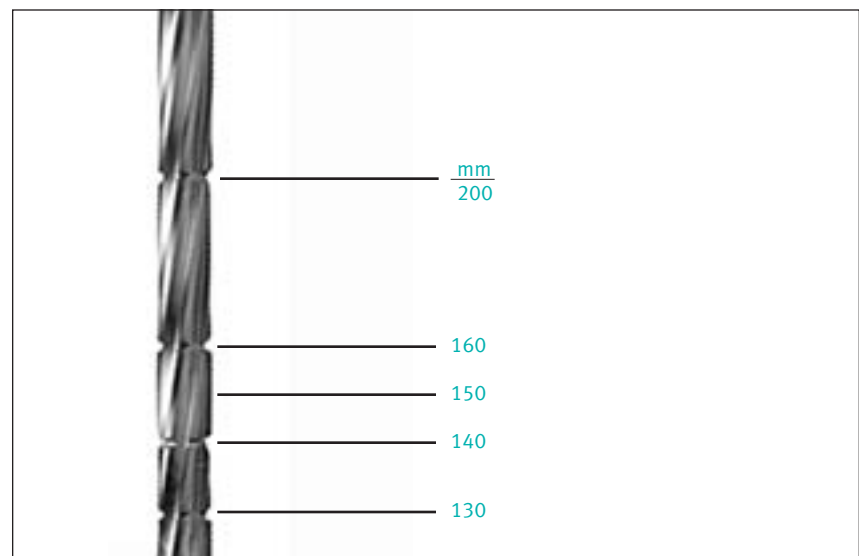

Table 2 - Corresponding Reamer Mark to Stem Lengths

Begin femoral reaming with IM reamers 3 or 4mm smaller than the anticipated prosthesis size. Sequentially increase the reamer size by 0.5mm increments, making sure that each reamer is advanced fully to its appropriate depth (Fig. 6). Ream until the desired canal diameter has been created. Line-to-line reaming is recommended (i.e., ream and rasp to 14mm and implant a size 14 prosthesis).

For large patients with wide proximal femurs and narrow distal femurs with dense cortical bone, it may be necessary to ream in order to seat the appropriate final rasp. The *VerSys* IM Taper Reamers (9801-41/46) can be used for these circumstances. These tapered reamers are smaller than the corresponding rasp (see Table 3). The indicated tapered reamer can be passed down the canal without violating the rasp envelope of the indicated rasp size. For a rasp size smaller than a 12, the IM Reamers can be used.



Fig. 6

Table 3 - Tapered Reamer and Corresponding Rasp

Tapered Reamer	RASP
1	12
2	13
3	14
4	15
5	16
6	17, 18, 19, 20

Attachment of the Rasp Alignment Tip (Optional)

NOTE: The Rasp Alignment Tip is only necessary if intramedullary reaming is performed.

Before impacting a Rasp, attach the Rasp Alignment Tip to the end of the Rasp (Fig. 7a) ensuring that the tip is fully engaged with the distal rasp threads (Fig. 7b). The Rasp Alignment Tips are labeled to correspond with their mating Rasp (i.e., a 14mm Rasp requires a 14mm Rasp Tip). The purpose of the Rasp Alignment Tip is to centralize the Rasp within the reamed canal and minimize malalignment of the Rasp which may cause the prosthesis to be positioned in varus or valgus. The Rasp Alignment Tips measure 1mm in diameter less than their labeled size to maintain appropriate distal clearance with a femoral canal while still centralizing the rasp in a reamed canal.

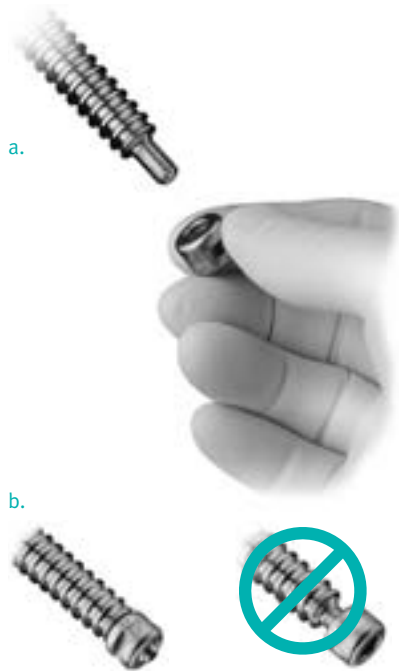

Fig. 7

Femoral Rasping

Begin the rasping sequence with a standard Rasp that is at least two sizes smaller than the estimated implant size. The VerSys Fiber Metal Taper stem should be implanted with the VerSys System Rasps (7892-009/020), or LM Rasps (7892-011/020-30) (Figs. 8a and 8b).

NOTE: Do not use the VerSys Enhanced Taper Rasps (7892-09/19-50) to implant the Fiber Metal Taper Hip Prosthesis.

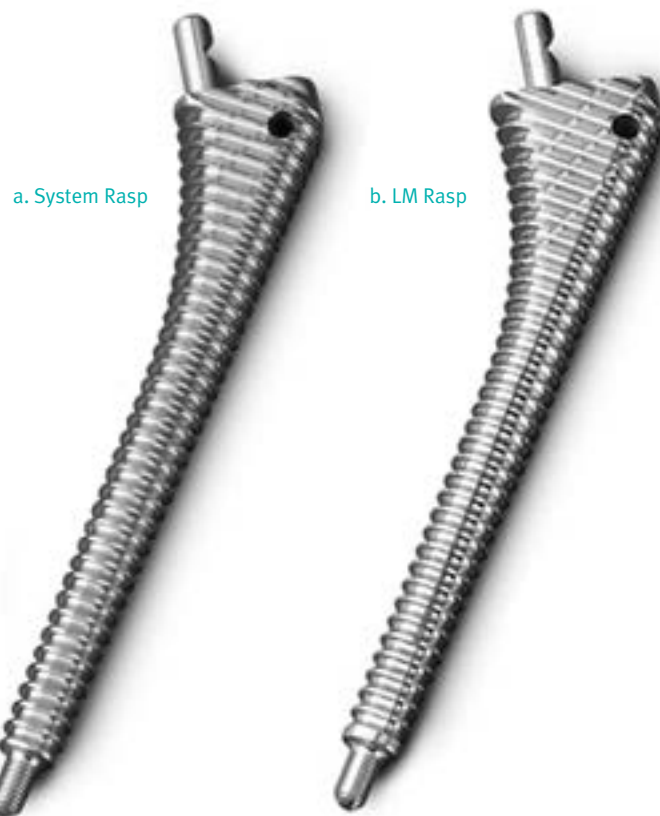

Fig. 8

When inserting the Rasp (Fig. 9), be sure that it advances with each blow of the mallet. If the Rasp can be seated at least 5mm below the osteotomy, progress to the next rasp size and repeat until the predicted final rasp size has been seated. If the predicted final rasp size can be countersunk more than 5mm and adequate cancellous bone is available in the metaphysis region, two choices are available for improved fit:

1. Progress to the next larger rasp size. This is recommended for cases where adequate cancellous bone is available on the anterior and posterior sides of the proximal femur and the distal medullary canal has enough room to accept the next larger size rasp. The distal canal may need to be reamed to a larger diameter to accept the next size implant.
2. Progress to the same size large metaphyseal (LM) Rasp. (LM Rasps are available in sizes 11mm through 20mm.) This option is recommended for cases where there is at least 4mm of cancellous bone medially and adequate cancellous bone on the anterior and posterior sides of the implant. Additional reaming is not required to use the corresponding LM implant.

NOTE: Once the LM Rasp has been inserted, a standard Rasp of any size cannot be used to prepare the canal and provide adequate fit with a standard implant.

NOTE: To countersink a size 9 or 10 Rasp, it may be necessary to use the Rasp Adapter to avoid the overhang of the Rasp Handle impinging on cortical bone. The Rasp Adapter attaches to the trunnion of the Rasp and connects to the Rasp Handle. When the Rasp is to be extracted, calcar planing may be needed. Also, the Rasp Handle must be attached directly to the Rasp Trunnion.



Fig. 9

Trial Reduction

Assemble the appropriately sized Porous/Enhanced Taper (POR/ET), or Extended Offset (EXT) Neck Provisional and Provisional Femoral Head to the Rasp and perform a trial reduction (Fig. 10).

Check the leg length and offset of the femur by referencing the lengths measured prior to dislocation of the hip. It is important at this stage to reposition the leg exactly where it was during the first measurement. Adjust the neck length by changing Provisional Femoral Heads to achieve the desired result. For the 28mm Femoral Head, the VerSys Hip System has five neck lengths (-3.5 to +10.5mm) which provide a total range of 14mm of neck length. When satisfactory leg length, offset, range of motion, and stability have been achieved, dislocate the hip.



Fig. 10

Insertion of the Femoral Component

Press the implant down the canal by hand until it will no longer advance (Fig. 11).

Place the Stem Impactor in the implant insertion slot located on the stem shoulder (Fig. 12). Begin to tap the Impactor Handle with a mallet until the prosthesis is fully seated or until the implant will no longer advance. The prosthesis should be seated until the most proximal part of the porous surface is level with the osteotomy line. If the implant is not advancing with each blow of the mallet, stop insertion and remove the component. Then rasp or ream additional bone from the areas that are preventing the insertion, and insert the component again.



Fig. 11

The Rasps and corresponding implants are sized such that a press-fit is created proximally. The most distal portion of the porous surface (medial side) is flush with the implant and gradually increases to 0.5mm proud (per surface) in the most proximal area. Thus, the implant is 1mm larger than the Rasp in both the A/P and M/L dimensions. This relationship can be seen on the templates. Therefore when the implant is seated, a 0.5mm press-fit per surface is achieved. Note that the metaphyseal press-fit engagement provides the implant with greater rotational stability than the Rasp.



Fig. 12

Attachment of the Femoral Head

Once the implant is fully seated in the femoral canal, place the selected Femoral Head Provisional onto the taper of the implant. Perform a trial reduction to assess joint stability, range of motion, and restoration of leg length and offset. When the appropriate femoral head implant is confirmed, remove the Femoral Head Provisional and check to ensure that the 12/14 taper is clean and dry. Then place the selected Femoral Head on the taper and secure it firmly by twisting it and striking it **once** with the Head Impactor. Test the security of the head fixation by trying to remove by hand.

NOTE: Do not impact the Femoral Head onto the taper before driving in the prosthesis as the Femoral Head may loosen during impaction.

Reduce the hip, and assess leg length, range of motion, stability, and abductor tension for the final time.

Wound Closure

After obtaining hemostasis, insert a *Hemovac*® Wound Drainage Device and close the wound in layers.

Postoperative Management

The postoperative management of patients with a *VerSys* Fiber Metal Taper implant is determined by the surgical technique, patient's bone quality, fit of the implant, and the surgeon's judgment.

VerSys Fiber Metal Taper Specifications

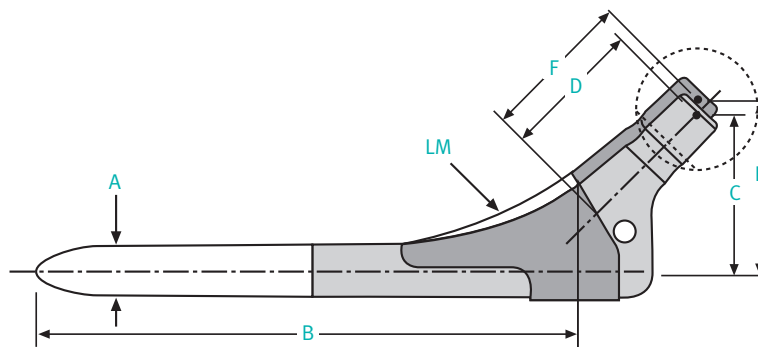

Fiber Metal Taper — Standard Offset

Prod. No. Standard*	Prod. No. w/LM Feature*	A Stem Size (mm)	B Stem Length (mm)	C Offset (mm) When Head / Neck Component Selected is:					D Neck Length (mm) When Head / Neck Component Selected is:				
				-3.5	+0	+3.5	+7	+10.5	-3.5	+0	+3.5	+7	+10.5
00-7862-009-00		9	110	30	33	35	38	40	24	28	31	35	38
00-7862-010-00		10	115	30	33	35	38	40	24	28	31	35	38
00-7862-011-00	00-7862-011-30	11	120	33	36	38	41	43	28	32	35	39	42
00-7862-012-00	00-7862-012-30	12	125	36	39	41	44	46	30	34	37	41	44
00-7862-013-00	00-7862-013-30	13	130	36	39	41	44	46	30	34	37	41	44
00-7862-014-00	00-7862-014-30	14	135	39	42	44	47	49	35	38	42	45	49
00-7862-015-00	00-7862-015-30	15	140	39	42	44	47	49	35	38	42	45	49
00-7862-016-00	00-7862-016-30	16	145	42	45	47	50	52	39	42	46	49	53
00-7862-017-00	00-7862-017-30	17	150	42	45	47	50	52	39	42	46	49	53
00-7862-018-00	00-7862-018-30	18	155	45	48	50	53	55	43	46	50	53	57
00-7862-019-00	00-7862-019-30	19	155	45	48	50	53	55	43	46	50	53	57
00-7862-020-00	00-7862-020-30	20	155	45	48	50	53	55	43	46	50	53	57

Fiber Metal Taper — Extended Offset

Prod. No. Standard*	Prod. No. w/LM Feature*	A Stem Size (mm)	B Stem Length (mm)	E Offset (mm) When Head / Neck Component Selected is:					F Neck Length (mm) When Head / Neck Component Selected is:				
				-3.5	+0	+3.5	+7	+10.5	-3.5	+0	+3.5	+7	+10.5
00-7862-011-20	00-7862-011-50	11	120	38	41	43	46	48	31	34	38	41	45
00-7862-012-20	00-7862-012-50	12	125	41	44	46	49	51	33	36	40	43	47
00-7862-013-20	00-7862-013-50	13	130	41	44	46	49	51	33	36	40	43	47
00-7862-014-20	00-7862-014-50	14	135	44	47	49	52	54	37	41	44	48	51
00-7862-015-20	00-7862-015-50	15	140	44	47	49	52	54	37	41	44	48	51
00-7862-016-20	00-7862-016-50	16	145	47	50	52	55	57	41	45	48	52	55
00-7862-017-20	00-7862-017-50	17	150	47	50	52	55	57	41	45	48	52	55
00-7862-018-20	00-7862-018-50	18	155	50	53	55	58	60	46	49	53	56	60
00-7862-019-20	00-7862-019-50	19	155	50	53	55	58	60	46	49	53	56	60
00-7862-020-20	00-7862-020-50	20	155	50	53	55	58	60	46	49	53	56	60

*The VerSys Fiber Metal Taper Hip Prosthesis is available with an HA/TCP coating. The product numbers for this option begin with a 65- prefix instead of a 00- prefix

This documentation is intended exclusively for physicians and is not intended for laypersons. Information on the products and procedures contained in this document is of a general nature and does not represent and does not constitute medical advice or recommendations. Because this information does not purport to constitute any diagnostic or therapeutic statement with regard to any individual medical case, each patient must be examined and advised individually, and this document does not replace the need for such examination and/or advice in whole or in part. Please refer to the package inserts for important product information, including, but not limited to, contraindications, warnings, precautions, and adverse effects.

CE
0086

Contact your Zimmer representative or visit us at www.zimmer.com

The CE mark is valid only if it is also printed on the product label.

